

THE CORVUS SERVICE MANUAL

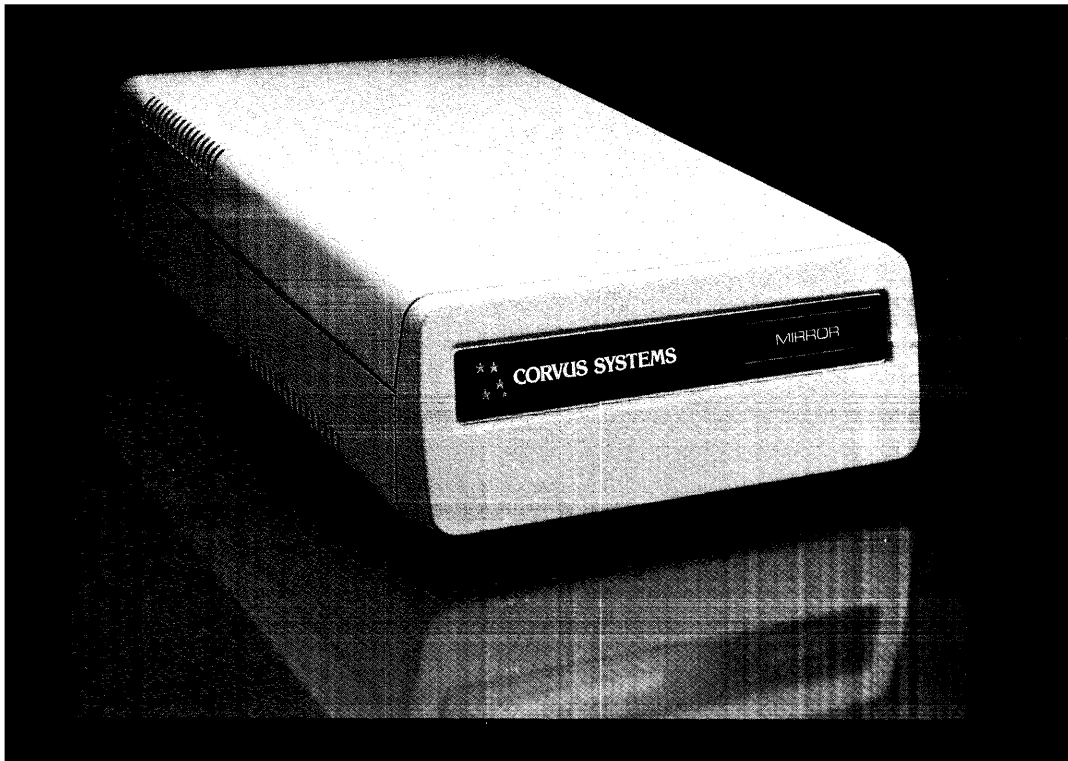

Mirror

***CORVUS SYSTEMS

DISCLAIMER OF ALL WARRANTIES & LIABILITIES

Corvus Systems, Inc. makes no warranties, either expressed or implied, with respect to this manual or with respect to the software described in this manual, its quality, performance, merchantability, or fitness for any particular purpose. Corvus Systems, Inc. software is sold or licensed "as is." The entire risk as to its quality or performance is with the buyer and not Corvus Systems, Inc., its distributor, or its retailer. The buyer assumes the entire cost of all necessary servicing, repair, or correction and any incidental or consequential damages. In no event will Corvus Systems, Inc. be liable for direct, indirect, incidental or consequential damages, even if Corvus Systems, Inc. has been advised of the possibility of such damages. Some states do not allow the exclusion or limitation of implied warranties or liabilities for incidental or consequential damages, so the above limitation may not apply to you.

Every effort has been made to insure that this manual accurately documents the operation and servicing of Corvus products. However, due to the ongoing modification and update of the software along with future products, Corvus Systems, Inc. cannot guarantee the accuracy of printed material after the date of publication, nor can Corvus Systems, Inc. accept responsibility for errors or omissions.

NOTICE

Corvus Systems, Inc. reserves the right to make changes in the product described in this manual at any time without notice. Revised manuals and update sheets will be published as needed and may be purchased by writing to:



Corvus Systems, Inc.
2100 Corvus Drive
San Jose, California 95124
(408) 559-7000
Telex 278976

This manual is copywrited and contains proprietary information. All rights reserved. This document may not, in whole or in part be copied, photocopied, reproduced, translated or reduced to any electronic medium or machine readable form without prior consent, in writing, from Corvus Systems, Inc.

Copyright© 1984 by Corvus Systems, Inc. All rights reserved.

Mirror® patent pending, The Corvus Concept,™ Transporter,™ Corvus OMNINET,™ Corvus Logicalc,™ Time Travel Editing,™ EdWord,™ Constellation,™ Corvus,™ Corvus Systems,™ Personal Workstation,™ Tap Box,™ Passive Tap Box,™ Active Junction Box,™ Omninet Unit™ are trademarks of Corvus Systems, Inc.

CP/M® is a registered trademark of Digital Research Inc.

Apple,® Apple II® and Apple II Plus® are registered trademarks of Apple Computers, Inc.

TRS-80® and Radio Shack® are registered trademarks of Tandy Corporation.

SuperBrain® is a registered trademark of Intertec Data Systems, Inc.

DEC,® LSI-11,® RL01® and RL02® are registered trademarks of Digital Equipment Corporation.

UCSD PASCAL™ is a trademark of the Regents of the University of California.

IBM® is a registered trademark of IBM Corporation.

Z-80® and Z-80A® are registered trademarks of Zilog, Inc.

FCC WARNING

This equipment generates, uses, and can radiate radio frequency energy and if not installed and used in accordance with the instruction manual, may cause interference to radio communications. As temporarily permitted by regulation it has not been tested for compliance with the limits for Class A computing devices pursuant to Subpart J of Part 15 of FCC Rules, which are designed to provide reasonable protection against such interference. Operation of this equipment in a residential area is likely to cause interference in which case the user at his own expense will be required to take whatever measures may be required to correct the interference.

CORVUS DEALER SERVICE

**CORVUS SYSTEMS
MIRROR
SERVICE MANUAL**

1
2
3
4
5
6
7
8
9
10
11
12
13
14
15
16
17
18
19
20
21
22
23
24
25
26
27
28
29
30
31
32
33
34
35
36
37
38
39
40
41
42
43
44
45
46
47
48
49
50
51
52
53
54
55
56
57
58
59
60
61
62
63
64
65
66
67
68
69
70
71
72
73
74
75
76
77
78
79
80
81
82
83
84
85
86
87
88
89
90
91
92
93
94
95
96
97
98
99
100

**MIRROR MANUAL
TABLE OF CONTENTS**

CHAPTER 1 — MIRROR OVERVIEW

1.0	Scope of Chapter	1
1.1	Introduction to the Corvus Mirror	1
1.2	Computer Compatibilities	1
1.3	Video Recorder Compatibilities	2
1.4	Video Tape Compatibilities	2

CHAPTER 2 — FUNCTIONAL DESCRIPTION

2.0	Scope of Chapter	4
2.1	Mirror Technical Overview	4
2.2	Video Format	5
2.3	External Signals	6
2.4	Component Interaction	8
2.5	Error Detection and Correction	9
2.6	Record Operation	10
2.7	Playback Operation	10

CHAPTER 3 — MIRROR INSTALLATION

3.0	Scope of Chapter	13
3.1	Connecting a Mirror to a Drive	13
3.2	Unpackaging and Parts Inventory	13
3.3	Installation	13
3.3.1	Internal Mirror	13
3.3.1.1	Installing an Internal Mirror in an 11 and 20MB Drive	13
3.3.1.2	Installing an Internal Mirror in a 6MB Drive	14
3.3.2	Stand Alone Mirror	16

CHAPTER 4 — MIRROR DIAGNOSTICS

4.0	Scope of Chapter	18
4.1	Mirror Diagnostics	18
4.2	Options	18
4.2.1	PRM Option	18
4.2.2	SUM Option	19
4.2.3	TST Option	19
4.2.4	ZERO Option	19
4.2.5	IMG Option	19
4.2.6	RES Option	19
4.2.7	VER Option	19
4.2.8	QUIT Option	19
4.3	MIRDIAG Usage	19
4.4	Mirror Error Codes	20

CHAPTER 5 — TROUBLESHOOTING

5.0	Scope of Chapter	21
5.1	Initial Troubleshooting	21
5.2	Troubleshooting Guide	22
5.2.1	Computer Can't Communicate with Drive	23
5.2.2	Stays Busy	23
5.2.3	Times Out	24
5.2.4	No Image Found	24
5.2.5	Faults Out	24
5.2.6	Excessive Soft Errors	25
5.2.7	Hard Errors	25

ILLUSTRATIONS

Figure 1.	Video Frame	4
Figure 2.	Video Format	5
Figure 3.	Video Signal	6
Figure 4.	System Block Diagram	7
Figure 5.	Control State Machine	9
Figure 6.	Record Mode	11
Figure 7.	Playback Operation	12
Figure 8.	Bottom Service Door with Mirror	14
Figure 9.	Video Connections	15
Figure 10.	Mirror Microswitches	15
Figure 11.	Drive Rear Bezel	16
Figure 12.	Stand Alone Mirror	17
Figure 13.	Monitor with Data Displayed	22
Figure 14.	Mirror Board with Scope Signals	26

SCHEMATIC DRAWINGS

10/20 MB Mirror Schematic	27
5 MB Mirror Schematic	28

CHAPTER 1
MIRROR OVERVIEW

CHAPTER 1 MIRROR OVERVIEW

1.0 Scope of Chapter

This chapter will familiarize you with the capabilities and compatibilities of the Corvus Mirror. You will also be familiarized with some of the terms that you will need to understand the general function of the Mirror.

1.1 Introduction to the Corvus Mirror

The Corvus Mirror provides an efficient and inexpensive backup for the Corvus family of Winchester disk drives. It also provides archival storage for large data base systems on a low cost, removable video cassette tape with the ability to store more than 70 Megabytes of data.

The Mirror is fully compatible with the standard NTSC video format used in the United States and also can be purchased in a PAL/SECAM version which is the standard video format used in European countries.

A Z80 microprocessor is used as a controller with the Mirror as a formatting interface to convert data from a digital signal to a video signal for recording on a video cassette recorder. The Corvus Hard disk uses the Z80 microprocessor resident on the controller card to provides an intelligent interface to the host computer. The host computer specifies one of three operations for the mirror: Write, Read or Verify.

In the Write operation, a portion of or an entire drive can be transferred to the cassette tape. The Read operation transfers the data from the tape to the disk and the Verify operation uses proven error detection procedures to ensure the readability of the data. This function provides a quick self-test to ensure the backup system is functioning correctly.

The Mirror contains Cyclical Redundancy Check (CRC) detection hardware using the standard CRC polynomial. Each block of 532 bytes consists of a header containing file information, 512 blocks of data and two bytes of CRC information.

Software is provided for each host computer and operating system to back up an entire disk or a selected portion of a disk.

1.2 Computer Compatibilities

The Corvus Mirror will interface with a wide variety of host computers. The following list represents our present interface product line to which the Mirror is capable of backing up.

Apple II	Superbrain
Apple III	TRS 80 Mod. I
Atari 800	TRS 80 Mod. II
Commodore	TRS 80 Mod. III
Hewlett Packard	Zenith
IBM Personal Computer	DEC Robin
NEC	S-100 Computers
Xerox 820	Sony

Future microcomputers interfacing with Corvus mass storage systems will also have Mirror backup capability.

CORVUS DEALER SERVICE

1.3 Video Recorder Compatibilities

Brand names and model numbers of video recording machines that have actually been used with the Mirror by Corvus or Corvus customers successfully are listed below. We recommend that customers interested in using a VCR not listed below test the recorder with a Mirror before the purchase is made.

Grundig	RCA
VCR 4000	VDP 150
Hitachi	VET 180
5000	VCT 201
Magnavox	VDT 350
8315	VDT 501
8325	VET/VFT 450
8335	VET 190
8345	Sylvania
Mitsubishi	VC 2210
VR 8313	Technicolor
National	212 (Maximum
NV 7000	recording time
Panasonic	= 30 minutes)
PV 1200	Quasar
PV 1210	VH 5011
PV 1270	VH 5015
PV 1370	VH 5210
PV 1470	VH 5310
PV 1770	VH 5610
VHS 1000	Zenith
VHS 1500	VL 9700 (Beta)
NV 1330	
NV 3700	
NV 8200	
NV 8310	
NV 8320	
NV 8410	

A remote option has been designed to allow complete unattended operation using the Panasonic NV 8200.

Various recorders on the market are equipped with a color enhancement feature. This feature confuses the Mirror by trying to superimpose color onto the backup image. Use of recorders with this feature should be avoided unless the customer has the expertise to disable the color enhancement circuitry in the recorder while using the Mirror.

1.4 Video Tape Compatibility

In order to obtain the lowest number of errors, a quality video tape should be used. Defective or worn tape can also cause problems when trying to backup. For that reason we strongly reemphasize the use of good quality tape for storage of your backup data. The Maxell Epitaxial has been selected for our inhouse use.

While performing backup, you should use the SP record mode with VHS recorders and Beta 1 mode (when available) with BETA recorders. The actual tape speeds for these modes and for the Technicolor 212 recorder are as follows:

VHS - SP Mode	1.31 IPS
BETA - Beta 1 Mode	1.57 IPS
Technicolor 212	1.26 IPS

CORVUS DEALER SERVICE

Although backups from several different days can be stored on a single tape, we recommend backing up each day with a different cassette in order to protect against destruction of your data. Magnetic or physical damage, accidental erasing or tape misplacement will not be a catastrophic loss if you have recorded each days image on individual tapes. The ratio of data storage to cassette lengths is listed below:

30 minute tape.....	18 MB
60 minute tape.....	36 MB
90 minute tape.....	55 MB
120 minute tape.....	73 MB

CHAPTER 2
FUNCTIONAL DESCRIPTION

CHAPTER 2 FUNCTIONAL DESCRIPTION

2.0 Scope of Chapter

In this chapter we will be describing the various components and devices in the Corvus Mirror interface board. Various areas covered will include Mirror Overview, Video Format, External Signal, Component Groups, Error Detection and Correction, Record Operation, and Playback Operation. We will communicate the technical concept of the Mirror devices and their functional interactions.

2.1 Mirror Technical Overview

The Mirror interface utilizes the Z80 microprocessor and 3K of RAM in the disk controller and is controlled through an 8 bit data bus and 7 control lines.

The combination of the intelligent Disk Controller and the Mirror data formatting interface converts the data from a digital signal to the proper format needed by the video cassette recorder for storage. The converted digital signal is analogous to a black and white picture with 2 identical frames recorded on it. Each frame is made up of 240 lines with certain lines reserved for vertical retrace and data is stored on 2 blocks of each frame. Figure 1 depicts the make up of a video frame.

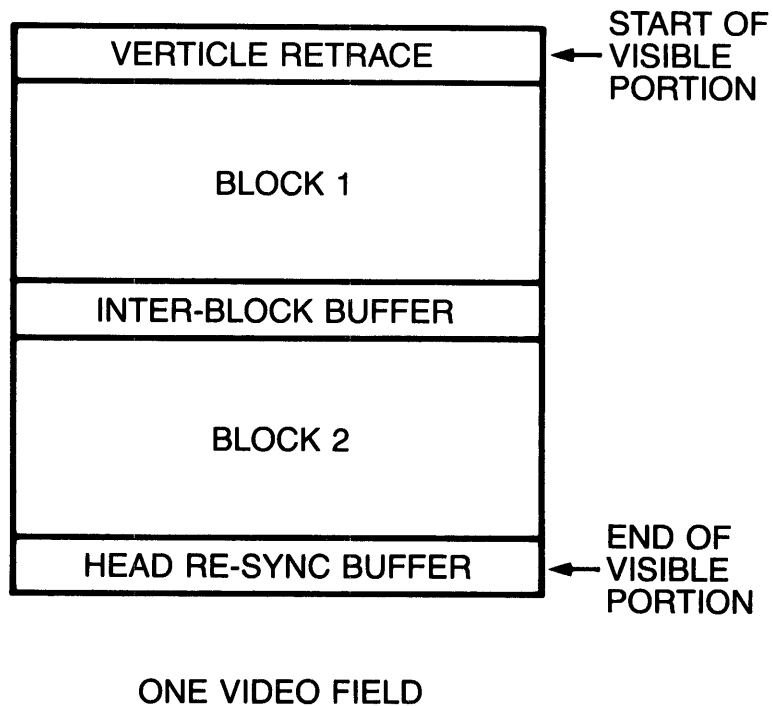

Figure 1. Video Frame

There are also three buffer fields that are part of each video frame. The first occurs during the vertical retrace signal and the first few lines of the visible portion. The purpose of this is to maintain a compatibility with future recording formats that may generate their own information during the vertical retrace "blank time". Interblock buffering allows for separation of blocks to avoid burst errors overlapping two blocks. A buffer at the end of the visible portion is necessary as the tapehead leaves the tape at the bottom of the visible portion in order to ensure that it reads a good vertical retrace signal. When the head leaves the tape, no data can be recovered, so another buffer is used which isolates that time from the data blocks.

The Video Timing Generator provides line and frame synchronization for the processor during record. The first block of data is transmitted following the vertical retrace and data is output through the I/O port into the shift register where it is converted from parallel to serial form. The data is then output from the I/O port at which time the 'handshake' occurs and the startbit is transmitted. The data byte is shifted out and at which time a stop bit is added. This data stream is 'summed' with the SYNC output of the video timing generator and level shifted to create the final video signal output.

The playback mode is essentially the inverse of record. As video signals are input to the interface, the SYNC information is separated and sensed by the microprocessor. The data bit stream is extracted by comparing the signal to a reference voltage halfway between the "black" and "white" signal levels. As the signal goes positive, the startbit is triggered and the microprocessor begins to sample the data stream at intervals corresponding to the bit time. Data bits are individually shifted in the shift register until eight bits have passed and the stop bit is recognized. The stop bit initiates the data handshake routine with the I/O port which then latches the data until it is read by the microprocessor.

2.2 Video Format

The DATA/SYNC information, header and error checking make up a data block. The SYNC header is provided to synchronize the reading of data to the start of that data. The SYNC hunt looks for the TYPE, FILE ID, and INVERSE FILE ID to indicate the start of the block (i.e. leader, data or trailer block).

To facilitate the tape positioning during file searches, each block contains a RELATIVE BLOCK number which relates to the first block and the number blocks in the file. For example, the first block is relative block number zero, the second block is relative block number one, etc.

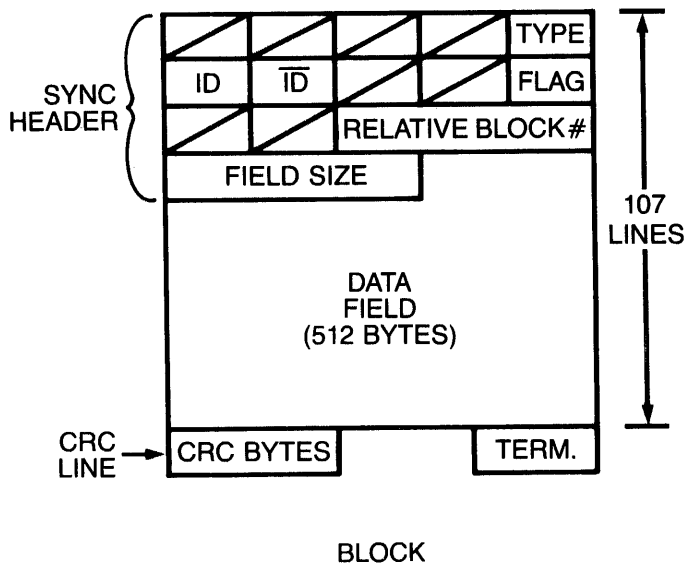

BLOCK
Figure 2. Video Format

CORVUS DEALER SERVICE

Two bytes are transmitted at the start of the last line that represents the CRC "SUM" of the block and they facilitate error detection on playback. The termination byte (TERM) is transmitted at the end of the last line. Its purpose is to reset the CRC generation circuitry on the mirror interface so that "good" CRC is only possible for a two byte time following the reception of the CRC bytes. Since good CRC can only be sampled during this brief window, the hardware will be able to detect loss of synchronization errors as CRC faults.

Each block is made of 107 lines with each line containing 5 bytes of information stored as a serial bit stream.

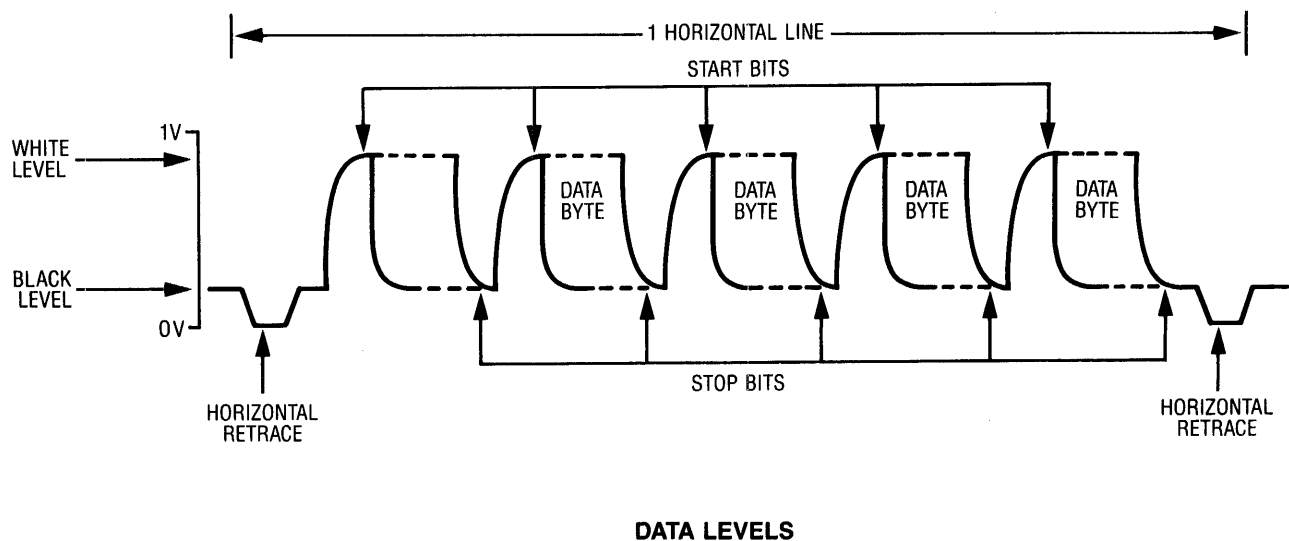

Figure 3. Video Signal

Figure 3 depicts the analog signal that is recorded as a line of data. "One" data is a high voltage "white level", and "zero" data is the "black" level. Horizontal retraces are triggered by video pulses below the "black" level (indicating the line boundaries for Television Video Standards).

Due to the high bandwidth and the necessity to interrupt data transmission during horizontal and vertical retrace, "START/STOP" serialization was implemented. The start of each byte was preceded by the transmission of a high level bit and following the byte, a low level bit is transmitted. "START/STOP", while having a high overhead, does provide better noise immunity and simpler circuitry to allow bit synchronization to an asynchronous/non-continuous data stream.

2.3 External Signals

The Mirror is controlled via the Data Bus, Ready, Strobe, SYNC, Alternate Select, Bus Direction and the SYNC. The Mirror interface responds to these lines and generates a video signal that can be recorded by a VCR or converts a video signal provided by the VCR into digital data to be stored onto the drive.

CORVUS DEALER SERVICE

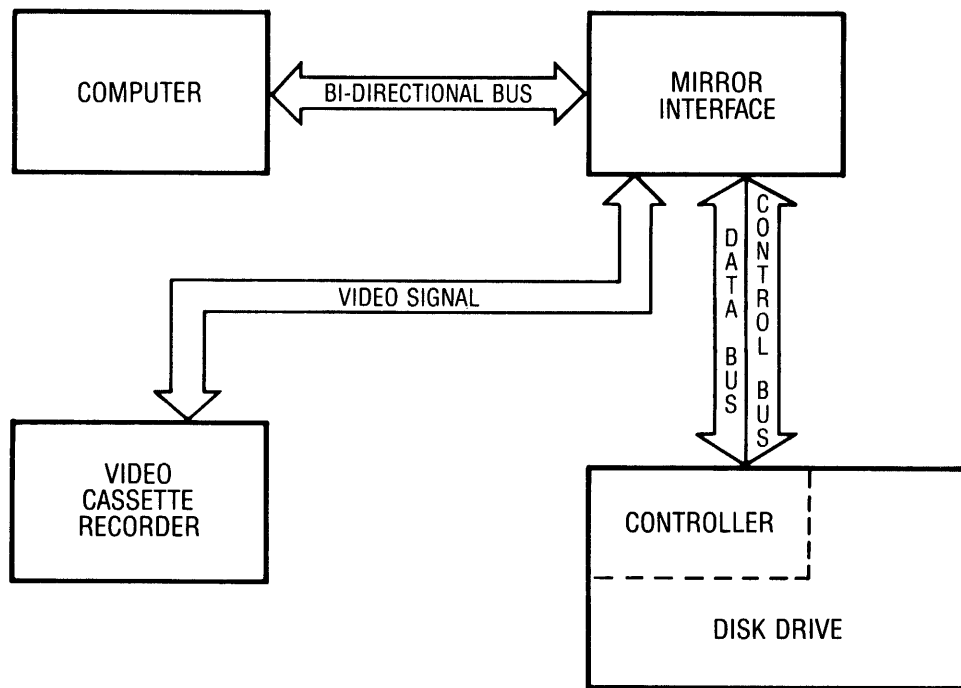

Figure 4. System Block Diagram

The data is transmitted on a bi-directional 8-bit parallel bus whose direction is controlled by the bus direction. The READY signal is provided by the controller to let the interface know that the data is ready on the bus. The interface responds with a strobe when the data is accepted and the controller then negates the ready signal.

When the controller is reading the data, the ready line indicates that the controller is ready to accept the data and the STROBE from the Mirror indicates the validity of the data on the bus.

The Error Correction hardware in the interface is controlled by three lines: the CRC Generator, the CRC Preset and the CRC Data Select line. The CRC Generator monitors the bit stream of the data being recorded and generates a "checksum" that is added to the block that follows the data. The CRC Preset initializes the state of this generator prior to the transmission at the beginning of the data. At the end of the data transmission the CRC/Data Select line is placed in the CRC mode in order that the Checksum data is transmitted onto the video signal. On playback, the bit stream is fed into the CRC generator and the Error Status line verifies the validity of the data following the reception of the data and the CRC bytes.

The SYNC line allows for the synchronization of the sending and receiving of the data to the predefined video frame standard of the horizontal lines. During the record, the SYNC line is generated by the interface and the controller synchronizes the data to the video generator. On playback the SYNC signal is separated from the data stream.

The only signal required to connect to the video recording medium are standard Video In/Out signals. The output is composite of the sync from the video generator and the data supplied from the controller. The input is only the recorded version of the output signal.

2.4 Component Interaction

The Mirror interface components can be grouped into eight major areas:

- Oscillator
- Video Standards Timing Generator
- Video Summing Circuit
- Control State Machine
- Shift Register
- CRC Generator
- Multiplexer
- Line Control Device

The signal from a 14.318 MHz Crystal is divided down to provide the 3.58 MHz signal for the Video Timing Generator and a 1.1 MHz signal for the data stream transmission clock (Phi Baud clock). The Phi Baud clock provides clock pulses for the Control State machine, providing data shifting information. The 5 bytes per horizontal line format can be altered to accommodate other line byte requirements (see Figure 5).

The Video Standards Timing Generator is used during record to provide for the standard television format that is then modulated with data. The SYNC output provides the external controller with timing information that is relevant to the beginning of the horizontal lines as well as retrace between video fields.

The SYNC signal and the data stream are added together by the Video Summing Circuit before being output to the video recorder. This circuit also provides standard analog levels.

On playback the SYNC and the data stream are extracted from the signal. The input analog signal is 'DC restored' along with the horizontal retrace pulses. These pulses are also separated from the signal to provide the SYNC lines. The data stream is recovered by comparing the video signal to the reference voltage midway between the black and white levels.

The Control State Machine provides the state controls for the Mirror interface. The operation is similar for both the record and playback modes. The initial WAIT state is ended with a READY startbit in record. In record mode, a strobe is sent to signal the acceptance of data. The next state either skips or generates the data startbit. After 8 more data clock states, data is shifted either into or out of the shift register. Another idle state follows which produces or skips the stop bit. In the final state, a strobe is sent to represent the valid data in the shift register. The controller then returns to a WAIT state.

The Shift Register is the heart of the data path. When in the record mode, the shift register is parallel loaded and data is then shifted out following the start bit. During playback the data is converted back from serial to parallel form.

The CRC Generator monitors the data stream on both the recording and playback modes. On record it generates the CRC 'checksum' and on playback it is added to the data stream to verify the validity of the recorded data.

The Multiplexer is used as a switch to control the inputs to devices in either the Read or Write modes. For example, the SYNC signal is outputted by the MUX and switches either the SYNC generated by the Video Timing Generator when in the Write mode or the SYNC generated by the input video signal in the Read mode. The R/W line determines the mode.

The Line Control Device is a group of components that provide the appropriate signals and controls, i.e. Preset, Error Status and Data/CRC Select to the Mirror interface. It is controlled via the ALT/SEL, BUS DIR and the DATA BUS signals from the Controller.

CONTROL STATE MACHINE

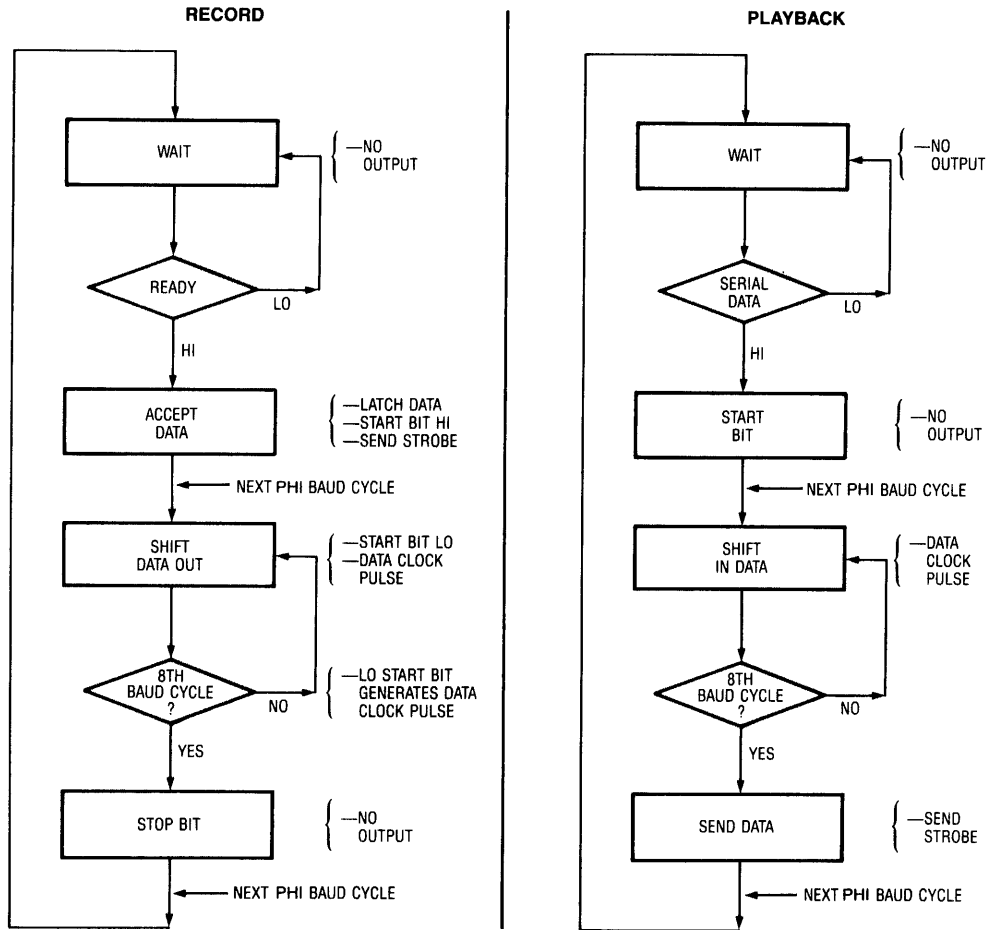

Figure 5. Control State Machine

2.5 Error Detection and Correction

Error detection is performed with a CRC checksum routine. In record, the data is sent to a CRC Generator (including the SYNC header). After the last byte is received, the CRC generator is put into the write mode and two bytes of the CRC 'sum' are added to the data stream.

On playback, the data stream and the CRC data bytes are input to the CRC Generator. Following the second CRC byte, the CRC indicator will change to indicate that the "sum" matches if no errors have occurred. The microprocessor samples the signal and validates the buffered data for proper synchronization and content.

Error correction is accomplished in two separate processes. First each block of data is recorded twice, once in the upper half of the video frame and once in the lower half (see Figure 1). Each frame is then recorded twice through software commands, providing quad redundancy to enhance data recovery capabilities.

CORVUS DEALER SERVICE

Error correction provides protection from scratches or imperfections on the video tape that may corrupt a number of blocks that are physically located in similar places on the tape.

There is still an excellent possibility of recovering data even if all blocks are corrupted. This is accomplished by comparing the two blocks in each frame to each other. If the block contains the same data, no errors are assumed. The blocks are compared at the beginning to find the first error and at the end of the block to find the last error. Because the errors are relative short bursts, it is unlikely that the bursts would overlap so that the companion block would likely have good data.

Reconstruction of the block is possible because the CRC bytes will indicate good data. At this point the first and last error position are averaged and this position is used as a breakpoint for the reconstruction of a good block. The first block is transmitted through the CRC checker up to the breakpoint, then the remaining data is transmitted from the second block. If the bursts were masked, the CRC checker will indicate valid data, if not, the transmission order is reversed and the burst will be masked out and the data recovered.

2.6 Record Operation

Initially the interface is in an idle state as the SYNC pulses from the video timing generator are transmitted to the external interface controller. With the R/W line in the WRITE mode, the data stream is selected from the shift register by the Data/CRC select signal (see Figure 6).

Data is placed on the bus and the READY line is set high by the external controller where it is then parallel loaded in the shift register. A STROBE pulse is returned to the external controller and then a Startbit is sent out of the state machine. This Startbit is added to the video sync signal to produce a 'white' signal.

Following a Phi-baud clock pulse, the Startbit is set low and the first bit of data is output serially to the video sum circuit. This produces a "black" signal if it is a 0 or a "white" signal if it is a 1.

After the next Phi-baud clock pulse, a Data Clock pulse is sent to the shift register which in turn clocks the next data bit to the serial output. This bit is then added to the video output signal and this process continues until all the bits are shifted out in a total of eight clock pulses.

When the last data bit has been transferred, the interface becomes idle for 1 clock pulse and the output of the video summer is 0. This state corresponds to the Stopbit time.

2.7 Playback Operation

The playback operation of the Mirror interface is very similar to the record mode as you will see, except that it is the inverse of that operation.

Beginning with the interface in an idle state, SYNC pulses are separated from the video input signal and are transferred to the external interface controller. With the R/W line in the Read mode, serial data out of the comparator is input to the shift register, the control state machine and the CRC generator/checker (see Figure 7).

A high level out of the comparator is interpreted as a Startbit. This triggers the Control State Machine to start inputting data.

Following a Phi-baud clock pulse, a data clock pulse is sent to the shift register from the Control State Machine which clocks the next data bit to the serial input. This continues for 8 clock pulses until all the bits are shifted into the shift register.

Following the 8th data clock pulse, the last data bit is decoded from the data stream and shifted into the shift register. The State Machine then sends a STROBE to indicate that the next byte of data is ready on the bus. With the shifting process idle, the State Machine enters a WAIT state on the next clock pulse. Again, this state corresponds to the stop bit time.

CORVUS DEALER SERVICE

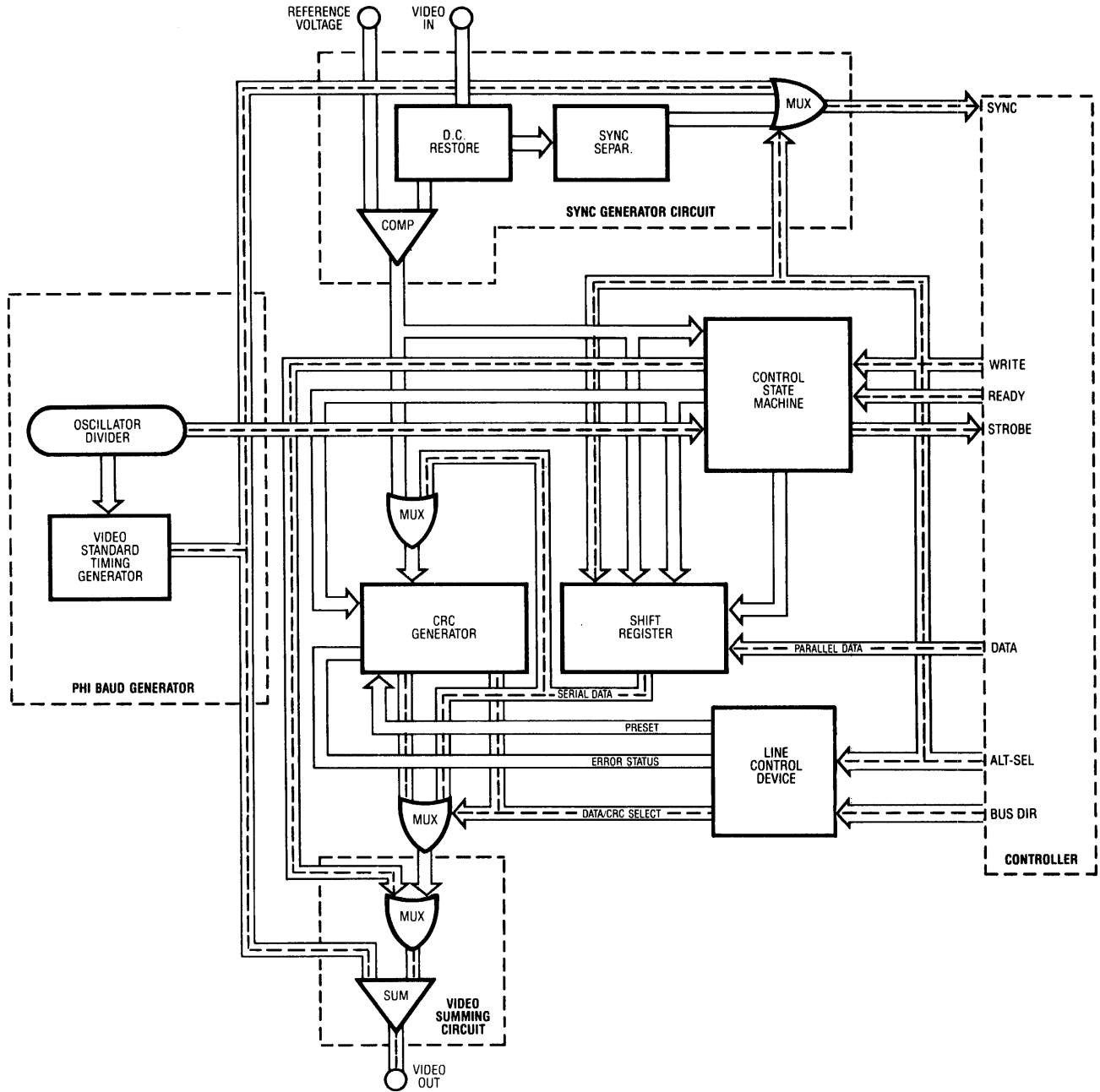

Figure 6. Record Mode

CORVUS DEALER SERVICE

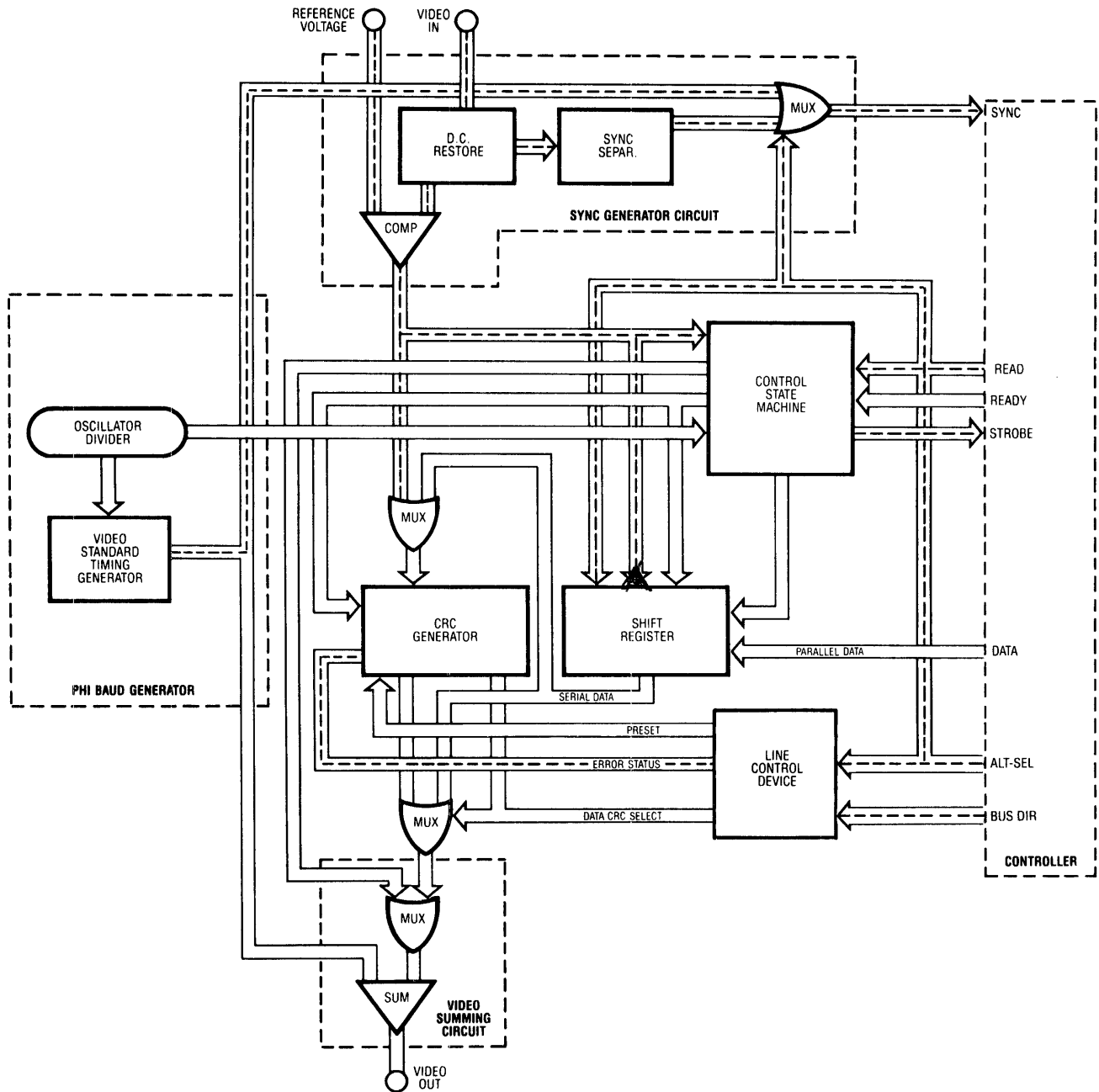

Figure 7. Playback Operation

CHAPTER 3
MIRROR INSTALLATION

CHAPTER 3 MIRROR INSTALLATION

3.0 Scope of Chapter

This Chapter will describe the unpackaging and installation of your Corvus Mirror. It contains step by step cabling procedures and diagrams for proper installation of both the self-contained Mirror and the stand alone version. The Remote option installation for the Panasonic NV8200 video cassette recorder is also described.

3.1 Connecting a Mirror to the Disk

The Corvus Mirror is packaged in one of two configurations: self contained within the drive cabinet or as a stand alone Mirror in its own enclosure.

The following installation procedures apply to both single user and network systems.

If you received a self contained Mirror, all connections between the drive and the Mirror have already been made. You need only to make the connections between the drive cabinet back panel and your video cassette recorder. The VIDEO OUT from the drive should be connected to the VIDEO IN of the VCR and the VIDEO IN plug of the drive should be connected to the VIDEO OUT of the VCR.

3.2 Unpackaing and Parts Checking

Carefully unpack the Mirror and check for shipping damage. Retain all packaging material and receipts in the event that any claims for shipping damage are filed. All damage claims should be filed promptly with the transportation company.

Your Corvus installation package should include the following items:

1. A Mirror (if you have ordered a stand alone Mirror, it is packaged in a white Corvus Mirror enclosure).
2. Corvus Mirror utilities diskette. (Only if you have ordered a separately packaged Mirror for an 11A Disk System or if your Corvus interface PROM is less than version 3.0. Otherwise Mirror utilities are on the Corvus Disk Drive utilities diskette that comes with your drive.
3. Dual phone plug cable for the VCR.
4. A flat ribbon cable with a 1 Mil connector at one end and double connectors, 1 Mil and 2 Mil, at the other.
5. Remote option cable (if you ordered the remote option with your Mirror).
6. Warranty Card

3.3 Installation

Be sure that the power to both the computer and to the Corvus drive is off anytime you install or remove any circuit cards or cables. Failure to do so may cause permanent hardware damage.

3.3.0 Internal Mirror

If you ordered a self-contained Mirror with your drive, the Mirror printed circuit board is located inside the drive cabinet. You only need to connect the video cable to the back panel of the drive cabinet.

NOTE:

If you are using a 6MB drive, verify that the microswitches on the rear bezel are set correctly (see Figure 10).

3.3.1 Installaing an Internal Mirror on a 11MB or 20MB Drive

If you are adding an internal Mirror to your drive follow the steps outlined below carefully for installation.

1. Turn the drive on it's side and remove the two allen head screws securing the trap door on the under side of the drive. Open the trap door (see Figure 8).
2. Mount the internal Mirror board onto the trap door with the hardware provided.

CORVUS DEALER SERVICE

3. Disconnect the drive flat cable from the male end of the processor flat cable (flat cable with double connectors) and install the 100 mil drive cable to the grey male connector on the Mirror board.
4. Install the female end of the processor cable (flat cable with double connectors) onto the black male 200 mil connector on the Mirror board.
5. Locate the white connector with four wires on the Mirror board and connect it to the matching connector going to the rear bezel.
6. Check to ensure that all connections are secure and close the trap door making sure that the cabling is not pinched.
7. Replace the hardware securing the trap door.

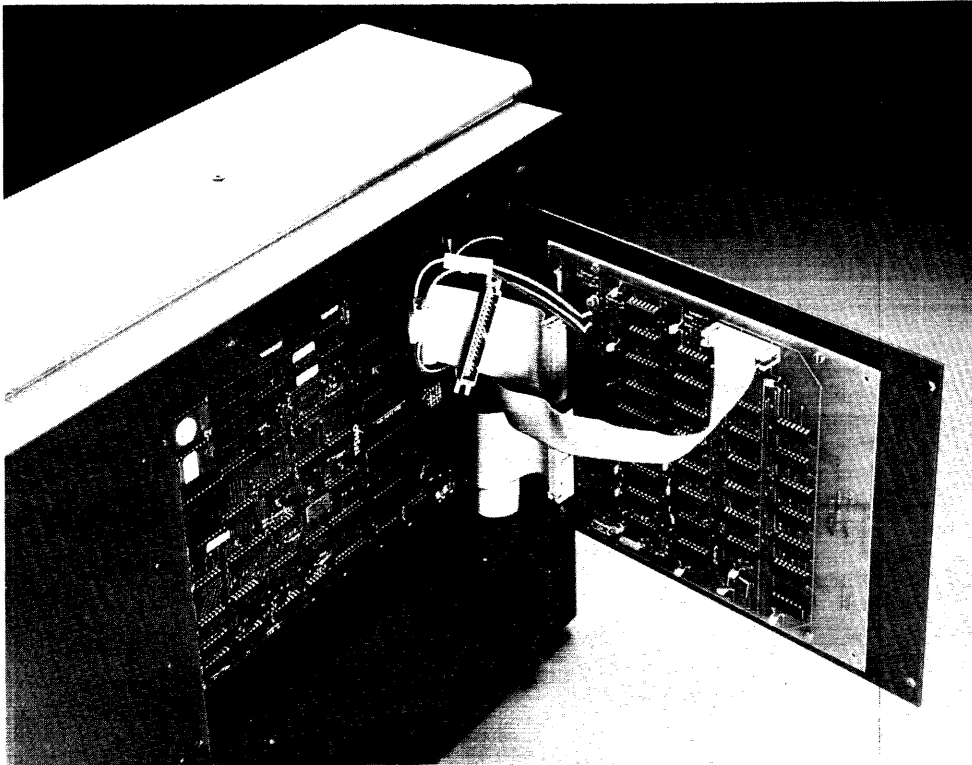

Figure 8. Bottom Service Door

8. Connect the video cable into the VIDEO OUT of the drive to the VIDEO IN of the VCR and the VIDEO IN from the drive to the VIDEO OUT of the VCR (see Figure 9).
9. If you are using a Panasonic NV8200 with the remote option, install the remote cable to the connector VCR Remote on the rear bezel (see Figure 9).

3.3.1.2 Installing an Internal Mirror in a 6MB Drive

1. Remove the allen head screws securing the top cover of the drive and remove the top.
2. Install the Mirror interface board into the vacant slot of the backplane which is attached to the top cover of the drive. Be sure that the component side of the board is facing out and that the board is well seated into the backplane and into the standoffs.
3. Replace the cover of the drive and reinstall the hardware.
4. There are a series of four microswitches on the rear of the drive.

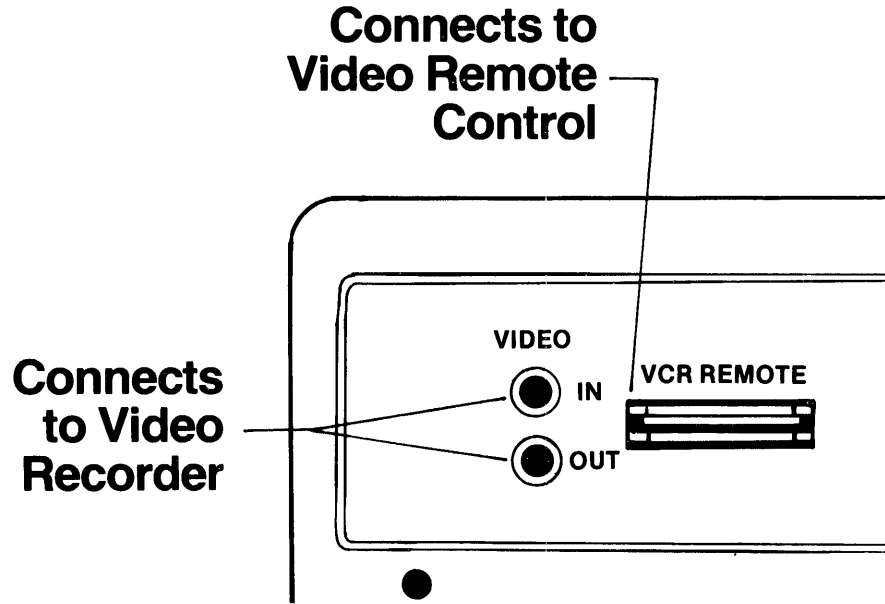

Figure 9. Video Connections

5 MB SWITCH SETTINGS

The dot indicates that the switch should be pressed **down** on that side.

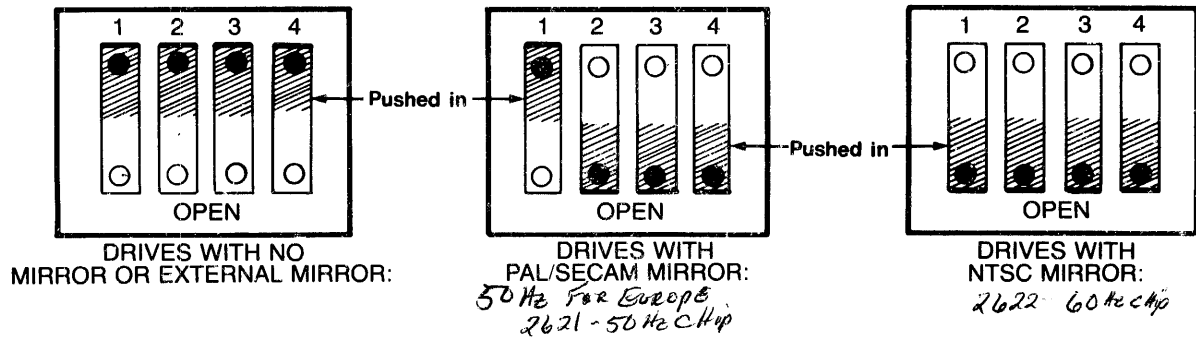

Figure 10. Mirror Micro Switches

When the internal Mirror is installed all switches should be in the open position, that is, all switches are pushed in at the bottom (see Figure 10).

Be sure that the switches are completely pushed in, as these switches have a tendency to rock back to their original position.

5. If the drive is of PAL/SECAM format (European), switch one will remain in the closed position (see Figure 10).
6. Install the video cable from the drive to the VCR, making sure that the video out from the drive is connected to the video in of the VCR and the video in of the drive is connected to the video out of the VCR.

3.3.2 Stand Alone Mirror

If you have ordered a Mirror to compliment an already existing Corvus drive, the Mirror is packaged in its own box and must be connected to the drive with flat cable. For stand-alone Mirrors, the Mirror is connected between the Corvus disk and the personality card that interfaces your computer to your Corvus hard disk. On network systems it is connected between your Corvus Disk and the Multiplexer or Disk Server.

You must detach the cable that connects the drive to the personality card, Multiplexer or Disk Server from the drive cabinet rear panel and attach the free end of this cable to the Mirror interface board. The flat cable supplied with the Mirror is then connected to the back panel of the drive cabinet and the Mirror interface board. Finally, the Mirror is connected to the VCR with the supplied phone plug cable. Incorrect cable installation will not allow proper operation of your Mirror.

1. To begin, remove the cover from the stand alone Mirror enclosure.
2. Detach the flat cable from the connector labeled PROCESSOR on the back panel of the drive cabinet. The end of this cable should be attached to the disk interface card (or a multiplexer or disk server if connected to a network).
3. Attach the cable that came with the Mirror to the back panel of the drive cabinet to the connector labeled PROCESSOR.

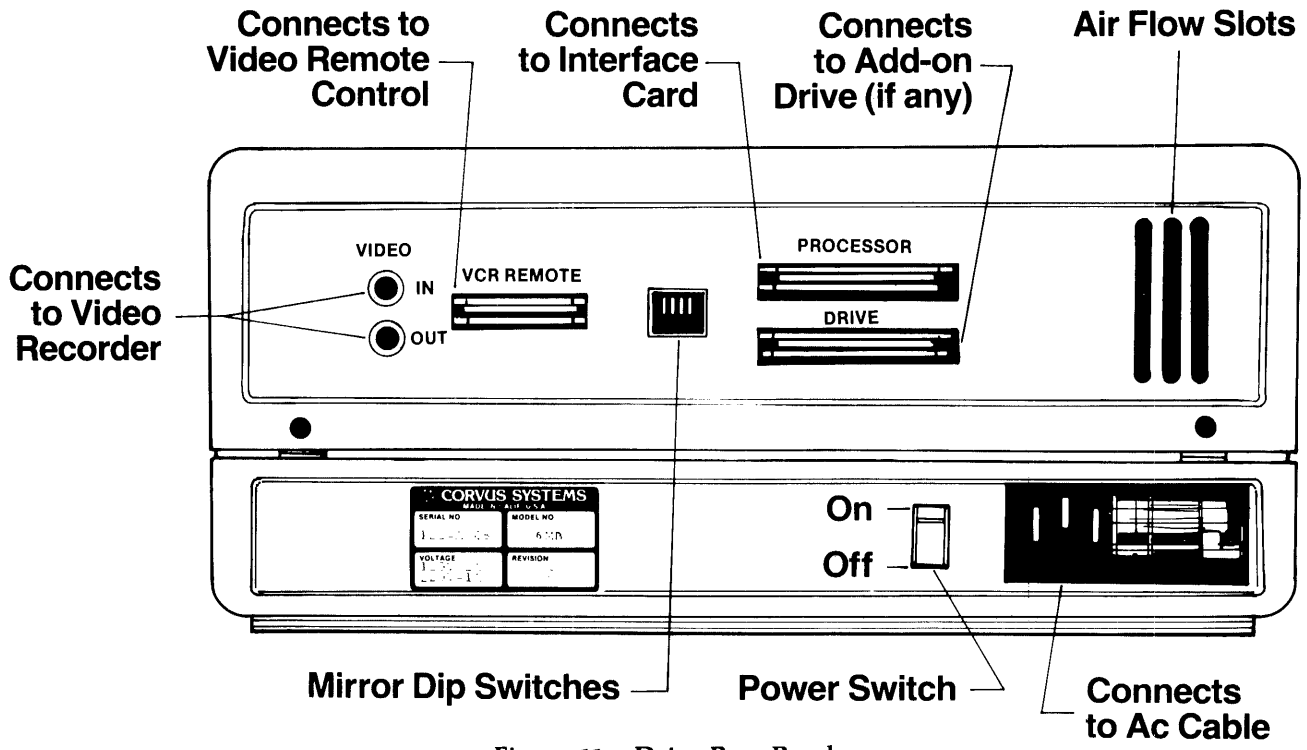

Figure 11. Drive Rear Bezel

Attach the other end of this cable to the drive connector on the Mirror interface board (see Figure 12).

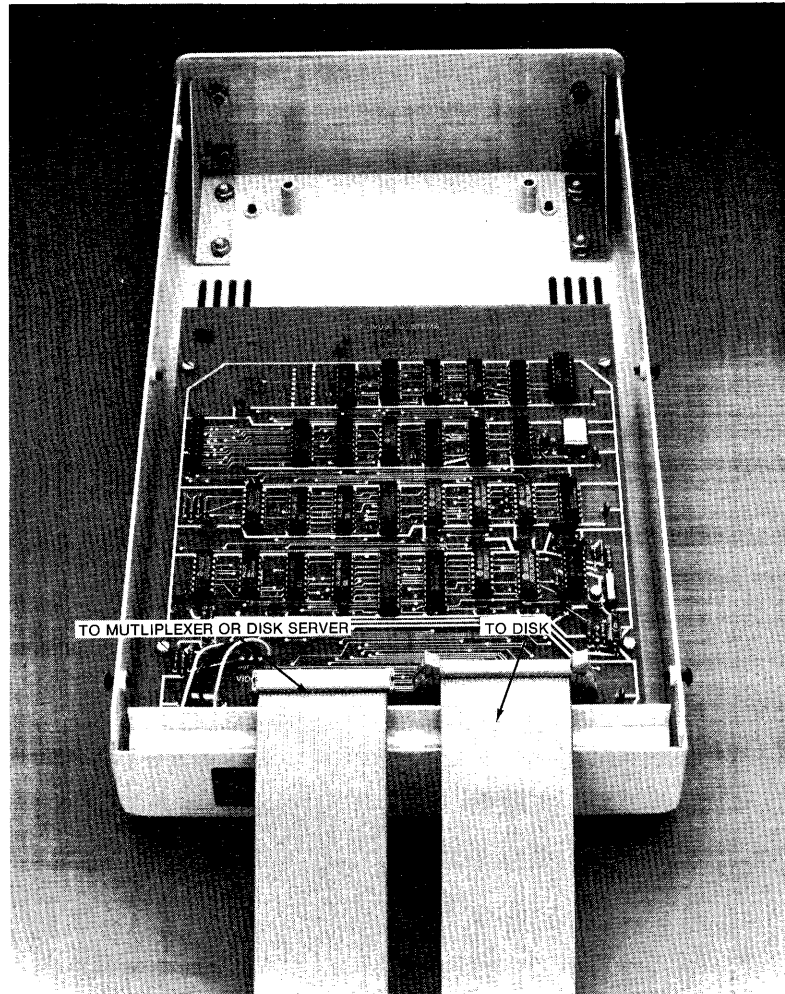

Figure 12. Stand Alone Mirror

4. Connect the cable from the interface card, Multiplexer or Disk server to the remaining 34 pin connector on the Mirror interface board (as shown in figure below).
5. If you have a 6MB drive, set the switches on the rear panel of your drive making sure that the switches are fully depressed (see Figure 10).
6. If you have ordered the Remote option, install the Remote Cable to the 20 pin male connector J3 on the interface board (see Figure 12).
7. When you are sure that all connections at the interface board are correct according to these instructions, reassemble the interface box and connect the ac cable.
8. To connect the phono plug cable, whether for a self-contained Mirror or a Stand Alone Mirror, be sure that the VIDEO OUT of the Mirror goes to the VIDEO IN of the VCR and the VIDEO IN of the Mirror comes from the VIDEO OUT of the VCR.

Reminder: THE REMOTE OPTION ONLY WORKS WITH A PANASONIC NV8200 VIDEO CASSETTE RECORDER.

CHAPTER 4
MIRROR DIAGNOSTICS

CHAPTER 4 MIRROR DIAGNOSTICS

4.0 Scope of Chapter

The intention of this chapter is to familiarize the reader with the Mirror diagnostic that are contained in the Dealer Service Diagnostic diskettes. These diskettes are designed to exercise the Mirror interface and can be used in conjunction with the troubleshooting procedures outlined in chapter five.

4.1 Mirror Diagnostics

The Mirror diagnostic program, MIRDIAG, provides a comprehensive test for the Mirror VCR interface.

The MIRDIAG program is a combination of Pascal and machine code programs which allow the technician to perform extensive tests of the Mirror interface board for short or extended time periods.

4.2 Options

MIRDIAG has a series of options which you can select to exercise the functions of the program.

4.2.1 PRM Option

The PRM (parameter) option allows you to set the test parameters. The following are a list of parameters and descriptions which can be set by the PRM option.

Loop Test/VCR Test — This option allows you to select tests with a VCR or optionally use a test drive with known good components to test a suspect drive and Mirror. The default value will be (VCR) for the VCR test.

Slot Number — This option allows you to select the computer slot which is connected to the drive under test. If VCR test has been selected, a single slot will be specified. The default slot for the VCR test will be slot 2. If loop test has been selected, then a sending slot and a receiving slot will be specified. The default value for the loop test will send slot (1) and receive slot (2).

Automatic VCR Control — With this option you will be able to specify whether automatic VCR control is to be used during testing. This option will only function with the Panasonic NV8200 VCR. The VCR must have the remote cable connected in order for this to operate correctly. The default value for VCR control is (Yes).

Block/Pass — The number of blocks per pass can be set during backup and restore operations by selecting this option. Default is (512) blocks.

Starting Address — The starting address can be specified for backup operations by using this option.

Restore Address — This option allows you to specify which address you wish to restore data to during the restore operation. The default value for Restore Address is (512). This must be greater than the last address backed up to ensure that the compare function operates properly.

Bidirectional Transfers — If you wish the Mirror transfers to be bidirectional during loop test, select this option. If you select Yes, the program will alternate backups and restores (or verifies) on each of the two slots specified. The default value is (N).

Restore/Verify — This option allows you to select restore or verify passes after the backup pass. For non-destructive testing, select the verify option. For more comprehensive testing, use the restore option, which will destroy data on the disk. The default value for Restore/Verify is (Verify).

Test Image — Test Image allows you to specify if a test image is to be written to the disk prior to backup. This option is destructive to data on the test disk. The default is (No).

Compare Records — You may request the computer to compare all records after a restore has been attempted by selecting this option. The computer will do a byte by byte comparison of the test image and the restored data. The computer will then report any miscomparisons. The default is (Yes).

Display Bad Bytes — This option allows you to view the results of any failed comparisons on a byte by byte basis. The computer will display the source and destination byte as well as relative sector and byte locations.

4.2.2 SUM Option

The SUM (Summary) option displays the cumulative results of the tests executed. All errors will be logged and accumulated from the time the program is started or the last zero.

4.2.3 TST Option

The TST option will start the test which you have selected from the parameters menu. You have the option of specifying the number of times the test is to be repeated.

4.2.4 ZERO Option

The ZERO option will zero the test counters so that the results of the previous test will not be added into the results of future tests.

NOTE:

The following four options are visible from the menu by pressing the question mark (?) key.

4.2.5 IMG Option

With the IMG option you can do a backup without automatic verify or restore. The image recorded will follow the same parameters set up in the PRM option.

4.2.6 RES Option

You can restore a recorded image under test using the RES option. Under this option you can specify the location where the data will be restored to. The block/pass parameter must match the size of the image recorded.

4.2.7 VER Option

The VER option allows you to verify a Mirror image. There are no parameters that affect this option.

4.2.8 QUIT Option

The QUIT option allows you to leave the Mirror diagnostic and return to the main diagnostic menu.

4.3.0 MIRDIAG Usage

The typical use for the Mirror program is to test the Mirror for functionality. If you have a Panasonic NV8200 with the remote cable, you can use the test as is, without changing any parameters. If you do not have a remote cable or have a different VCR, you can use the parameter option to change the automatic VCR control option. Use the default values for all other parameters. After the parameters are set, use the TST option to start the test procedures. We recommend that you run 2 to 4 passes for each Mirror.

On a 512 block test, you should get approximately 10 soft errors per pass. If you perform 2 tests, the total should be approximately 20 (remember that all tests are cumulative until you zero the counters). Most other types of recorders will yield a higher soft error rate. Under no circumstances should there be any hard errors. If hard errors do occur, there is most likely a problem in the Mirror card.

Under no circumstances should you encounter CRC errors or Disk Errors on backup. If you encounter these errors, run the drive diagnostics to check out the integrity of the data on the drive. It is very likely that there are media defects on the drive if disk errors are encountered.

Compare errors indicate that the data recorded did not match the data restored. If this occurs, check to make sure that you have not changed the parameters of the test between the time that you performed backup and restore. Also, the restore address must be greater than or equal to the sum of the starting address and the number of blocks per pass. If this is not true, a miscompare will result. If a miscompare results due to a real failure, the most likely cause will be the link between the controller and the Mirror. Note that the computer interface card is on the same parallel data bus and can also be the culprit.

4.4.0 MIRDIAG Error Codes

The following is a list of error codes that may be encountered during the operation of the MIRDIAG program.

MIRROR ERRORS

Error Code	Description
1	File ID mismatch
2	Invalid restore command
3	Invalid retry command
4	File size mismatch
5	Invalid opcode
7	Start of image not found
8	Position error
134	Tape dropout during playback

CHAPTER 5
TROUBLESHOOTING

CHAPTER 5 MIRROR TROUBLESHOOTING

5.0 Scope of Chapter

This chapter will serve to guide you through troubleshooting the Corvus Mirror interface in the event that you should encounter difficulties in operation. While some of the problems you may experience might seem to be hardware malfunctions, they may be created by other causes. To facilitate the isolation of any problem, we have organized our troubleshooting approach to reflect the indications that you would see during the Mirror operation. These indications are organized into the following categories:

- STAYS BUSY — The busy light remains lit.
- TIMES OUT — Returns to the ready state very quickly.
- FAULTS OUT — Goes to fault status and remains in that state.
- ERRORS — Reports hard errors or an excessive amount of recovered soft errors.
- NO IMAGE FOUND — Image header not found during a Restore, Verify or Identify.

Many of these indications may occur due to operational and installation mistakes, video equipment failure or hardware failures other than the Mirror interface. In this chapter we will be addressing the lower level complications as well as some of the more complex problems that would require digital troubleshooting skills. We have identified selected test points in our troubleshooting guide and have attached schematics in the appendix to offer low level troubleshooting capabilities to qualified service technicians.

5.1 Initial Troubleshooting

The initial approach to troubleshooting any system is to eliminate the most obvious causes which may be creating the problem. We recommend the following procedures that are outlined in the Quick Checks to ensure that a simple oversight may not be the culprit.

QUICK CHECKS

1. Be sure that your drive is functioning properly with your computer. If your computer has problems communicating with the drive, disconnect the Mirror interface and make another attempt. If it works, there is definitely a Mirror hardware problem because all data lines and control lines pass through the Mirror interface when it is installed.
2. Using a DC Volt meter, check for 5VDC at the 27 pf capacitor located next to J1 on the Mirror interface board. Check from the positive side of this cap to ground. It should vary no more than + or -.1 volt.
3. Check to see that all settings on the VCR are correct. Video cassette recorders differ and offer various options, but the following standard switches should be set accordingly:
 - Turn off any accessories not needed
 - Input switch should be on 'line'
 - TV/VTR switch should be set to VTR
 - Tracking should be set to midrange
 - Tape speed should be set to midrange

NOTE:

Most VCRs have detents on tracking and play speed adjustments. Set these at detent.

4. Verify that the installation of the video cables is correct, i.e. VCR video out to Mirror video in and VCR video in to Mirror video out. Check for corrosion at the connectors and replace if necessary.

5. One test for checking the continuity of the video connectors, video cables and Mirror circuitry is to do the LOOP BACK test. Simply connect the video out of the Mirror to the video in of the Mirror, essentially looping the signal back in. Run an Identify operation and, after 2 minutes and 35 seconds, the Mirror should time out.
6. Ensure that tape positioning is correct. Improper positioning can cause the image header to be missed which will hang the operation.
7. A quick way to check if data is being transmitted from the drive during a backup, or from the VCR during a restore is to connect the video out cable to the monitor. The photograph below illustrates data as it should be seen on the monitor.

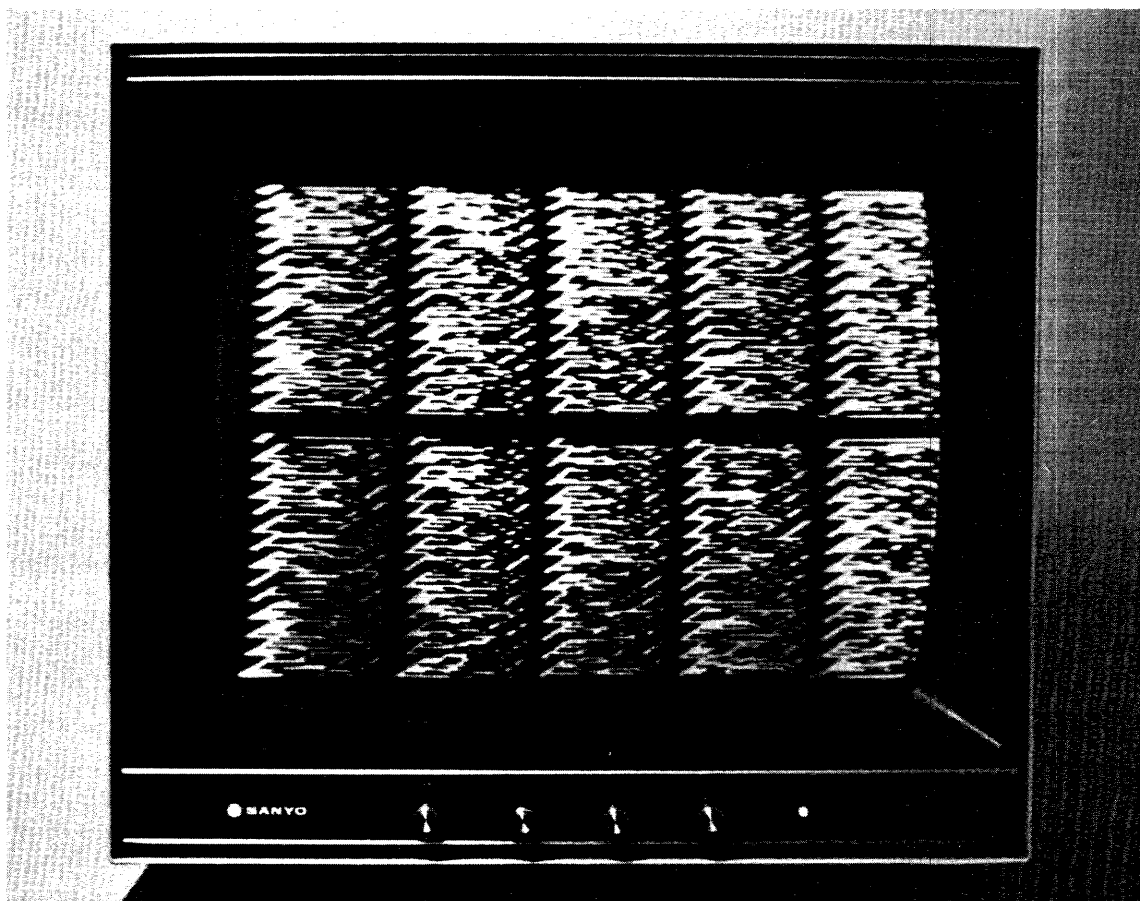

Figure 13. Monitor with Data Displayed

5.2 Troubleshooting Guide

The following guide has been based on symptoms that may be encountered if a Mirror malfunction occurs during an operation. It is designed to point the qualified service technician toward a possible cause of the problem. The initial indications are described, as are the probable causes and the Test Points.

A troubleshooting guide has been included to facilitate servicing. Photographs are provided of test points and of signals that should be seen at those test points.

TROUBLESHOOTING GUIDE

SYMPTOMS	POSSIBLE CAUSE	TROUBLESHOOTING PROCEDURE
Drive does not communicate with computer.	Loose connection	STAND ALONE MIRROR: Check cable at the rear of drive to ensure proper connection. Remove top of Mirror and check for proper cable installation. (See section 3.3.2 in this manual.)
	No +5VDC	Check for 5VDC as described in Quick Check 2.
	Switch Settings	6MB INTERNAL MIRROR: Check the microswitch setting at the rear bezel (see Figure 10) for proper setting. Remove top of drive and check to see that the Mirror board is seated well into the backplane. Also check flat ribbon connector at the rear bezel of the drive.
	Loose connection	11/20MB DRIVE: Open service door on bottom of drive and check all connections (see section 3.1.1.1 in this manual). Also check flat ribbon connector at the rear bezel of the drive.
	Soft Reset continually on.	Check TP 4. It should be constantly high (5VDC). If okay, check U3 for proper operation.
STAYS BUSY	Incorrect video signal	Check to see that the proper IC is inserted at U30 (2622 for NTSC format and 2621 for PAL/SECAM format). If okay, check Q1 (see schematic).
	Switch settings (6MB)	Check the microswitch setting at the rear bezel (see Figure 10) for proper setting.
	No video signal	Check Mirror board for broken wires on video in line.
	Serial data not being generated.	Check TP 2 for correct signal. If not okay, see schematic.
	ALT/SEL signal is not selecting properly for data signals and command signals.	Check TP 13 for low signal during data transfer.
TIMES OUT	Not receiving data.	Check cable connections (Quick Check 3).
		Check TP 1 for proper signal.

CORVUS DEALER SERVICE

SYMPTOMS	POSSIBLE CAUSE	TROUBLESHOOTING PROCEDURE
TIMES OUT (continued)	Bus direction improper.	Check TP 10 for proper signal. Should be high during record and toggling during playback.
	Mirror not enabled.	Check TP 9 for low signal.
	No Startbit.	Check TP 5 for proper signal.
	No SYNC pulse.	Check TP 11 for high signal.
	Phi Baud	Check TP 7 for proper signal.
	No STROBE signal.	Check TP 12 for proper signal.
NO IMAGE FOUND	No stop bit.	Check TP 6 for proper signal.
	Tape position error.	Perform quick check 5.
	Low quality, damaged or worn tape.	Replace video tape and retry operation.
	Backup not good.	Perform Verify operation. If Verify not successful, redo backup.
	No input to Mirror from VCR.	Perform quick check 5 to check signal from VCR.
	Video input circuit defective.	Check TP 3 for proper signal.
	Bus direction improper.	Check TP 10 for proper signal. Should be high during record and toggling during playback.
	Mirror not enabled.	Check TP 9 for low signal.
	No Startbit.	Check TP 5 for proper signal.
	No SYNC pulse.	Check TP 11 for high signal.
	Phi Baud	Check TP 7 for proper signal.
	No STROBE signal.	Check TP 12 for proper signal.
	No stop bit.	Check TP 6 for proper signal.
VISYNC defective.	Check TP 8 for proper signal. Check Q2, Q3 and supportive circuit (see schematic).	
FAULTS OUT	6MB microswitches set improperly.	See Figure 10 in the installation section of this manual.
	DATA/CONTROL line shorted.	Check for proper cable installation of flat cable. Check for shorts on U6 between pins 16,4,15,5,14,6,13 and 7. Also check for defective chips on data/control line.
	CRC chip generating errors.	Check TP 15 for high signal. If not okay, see schematic.
	SYNC signal bad	Check TP 11. If not okay, see schematic.

CORVUS DEALER SERVICE

SYMPTOMS	POSSIBLE CAUSE	TROUBLESHOOTING PROCEDURE
FAULTS OUT (continued)	Phi Baud circuit defective.	Check TP 7 for proper signal. If not okay, check appropriate input to flip flop, including the "soft" five volt line.
	Bus direction improper.	Check TP 10 for a toggling signal during playback and a high signal during record.
	Defective Video Frequency chip.	Check TP 14 for proper signal. Check to see that the proper IC is inserted at U30 (2622 for NTSC format and 2621 for PAL/SECAM format.
	Bus direction improper.	Check TP 10 for proper signal. Should be high during record and toggling during playback.
	Tape position error.	Perform quick check 5.
EXCESSIVE SOFT ERRORS	Low quality, damaged or worn tape.	Replace video tape and retry operation.
	VCR heads dirty.	Clean VCR record and playback heads.
	Backup not good.	Perform Verify operation. If Verify not successful, redo backup.
	CRC chip malfunction.	Check TP 15 for proper signal. If not okay, see schematic.
	Oscillator circuit bad.	Check TP 16 for proper frequency.
HARD ERRORS	Parallel/Serial conversion malfunction.	Check TP 1 & TP 2 for proper signal. If not okay, see schematic.
	DATA/COMMAND line short.	Check for shorts on U6 between pins 16,4,15,5,14,6,13 and 7. Also check for defective chips on data/control line.
	Bad IC on DATA/COMMAND lines.	Check ICs on DATA/COMMAND lines. U5 and U6 are common failures.
	Video input circuit defective.	Check TP 3 for proper signal.
	Bus direction improper.	Check TP 10 for proper signal. Should be high during record and toggling during playback.
	Mirror not enabled.	Check TP 9 for low signal.
	No Startbit.	Check TP 5 for proper signal.
	No SYNC pulse.	Check TP 11 for high signal.
	Phi Baud	Check TP 7 for proper signal.
	No STROBE signal.	Check TP 12 for proper signal.
	No stop bit.	Check TP 6 for proper signal.
Defective VCR.	Replace VCR.	

MIRROR TEST POINTS

TEST POINT	SIGNAL NAME	LOCATION CHIP/PIN	OSCILLOSCOPE SETTINGS
1	SERIAL DATA IN	U6/18	1 μ s @ 1V/Div
2	SERIAL DATA OUT	U6/8	.5 μ s @ 1V/Div
3	VIDEO IN	U9/4	2 μ s @ .2V/Div
4	RESET	U3/1	2V/Div
5	STARTBIT	U8/11	.5 μ s @ 1V/Div
6	STOPBIT	U8/10	.1 μ s @ 1V/Div
7	PHI BAUD	U27/9	200ns @ 2V/Div
8	VISYNC	U8/13	50 μ s @ 1V/Div
9	ENABLE	U3/2	2V/Div
10	BUS DIRECTION	U8/1	2V/Div
11	SYNC	U19/10	50 μ s @ 1V/Div
12	STROBE	U15/4	50 μ s @ 1V/Div
13	ALT/SEL	U7/4	2V/Div
14	VIDEO FREQUENCY	U30/1	2V/Div
15	CRC	U2/13	2V/Div
16	OSCILLATOR	U23/12	10 μ s @ 1V/Div

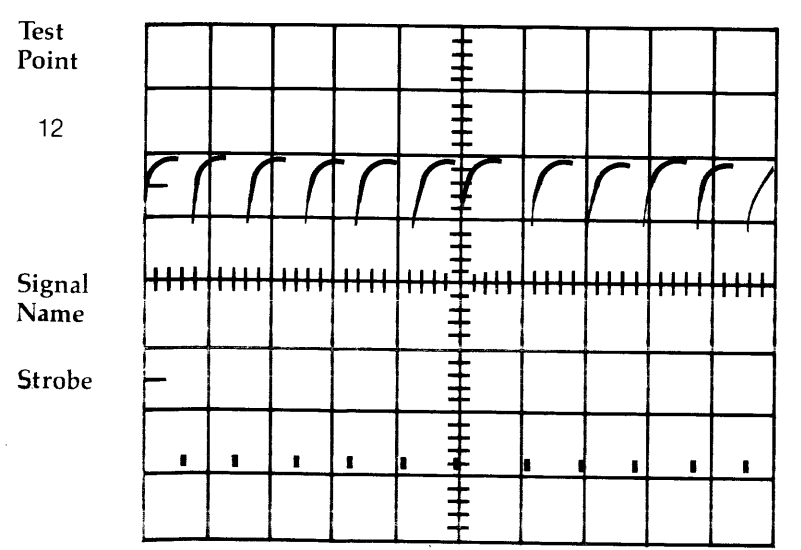
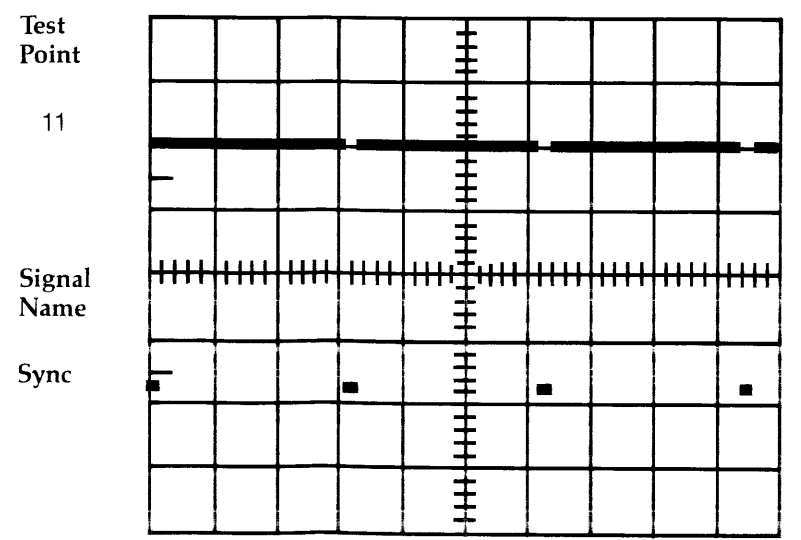
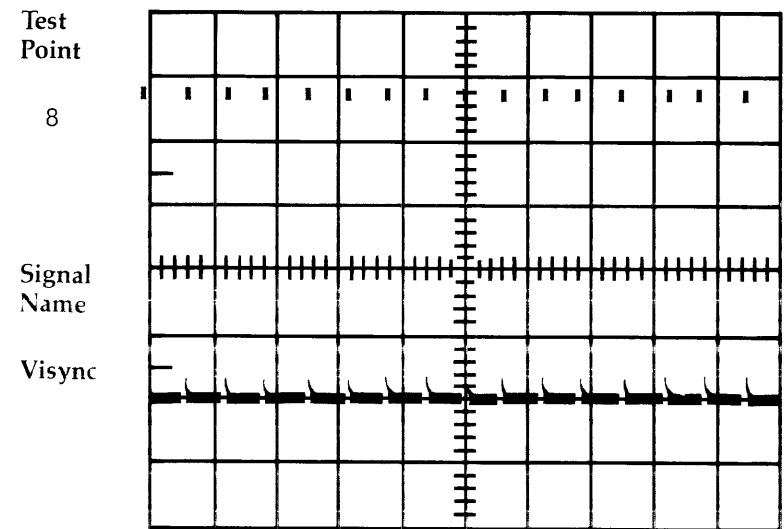
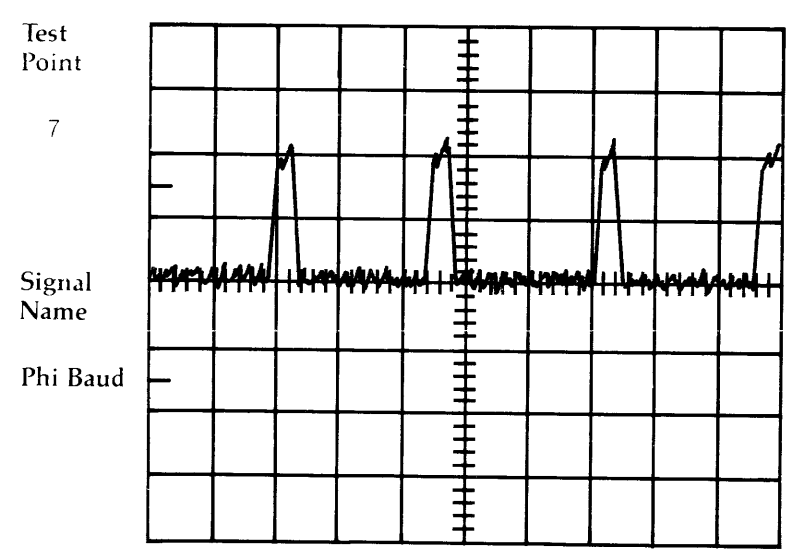
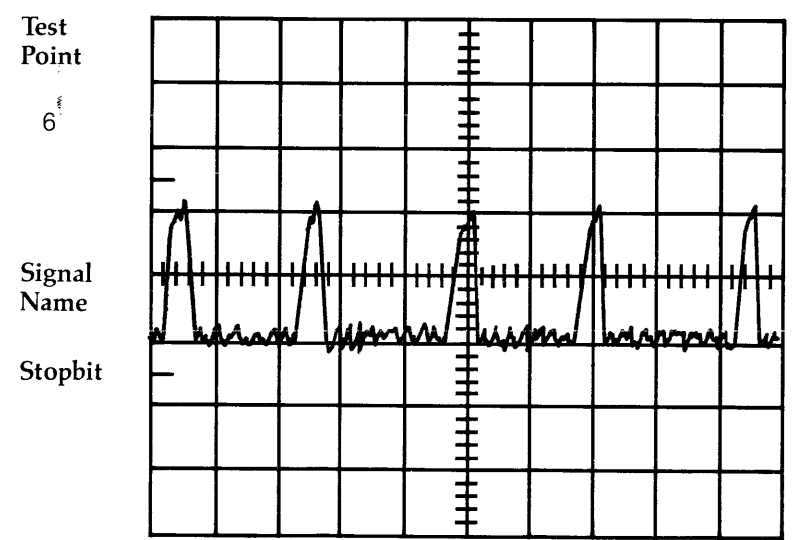
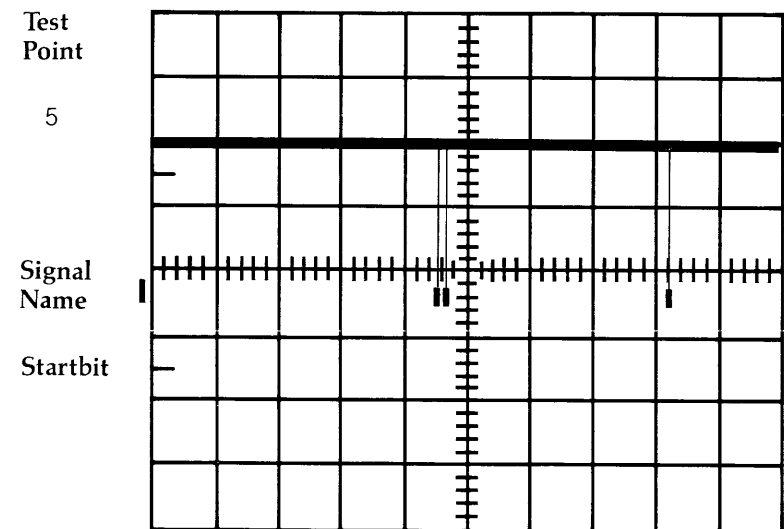
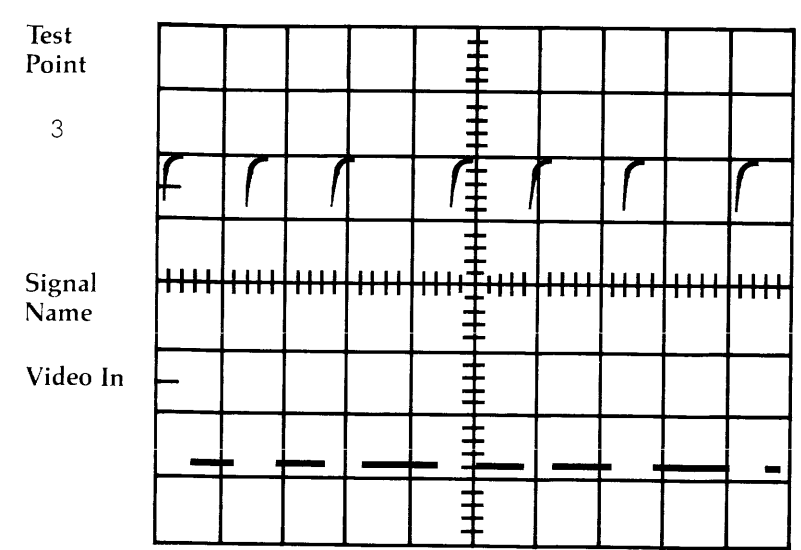
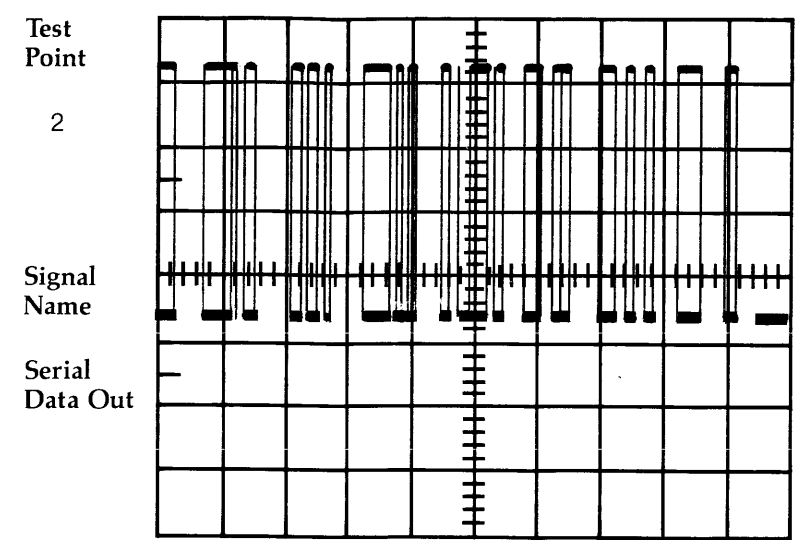
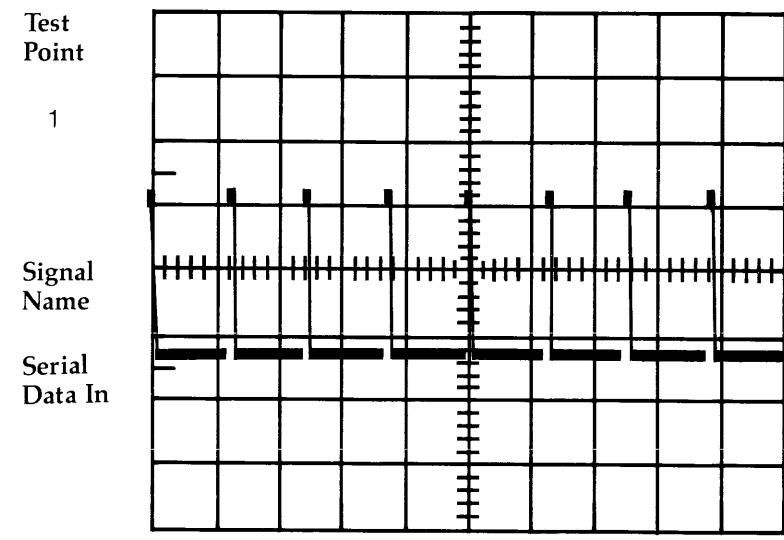

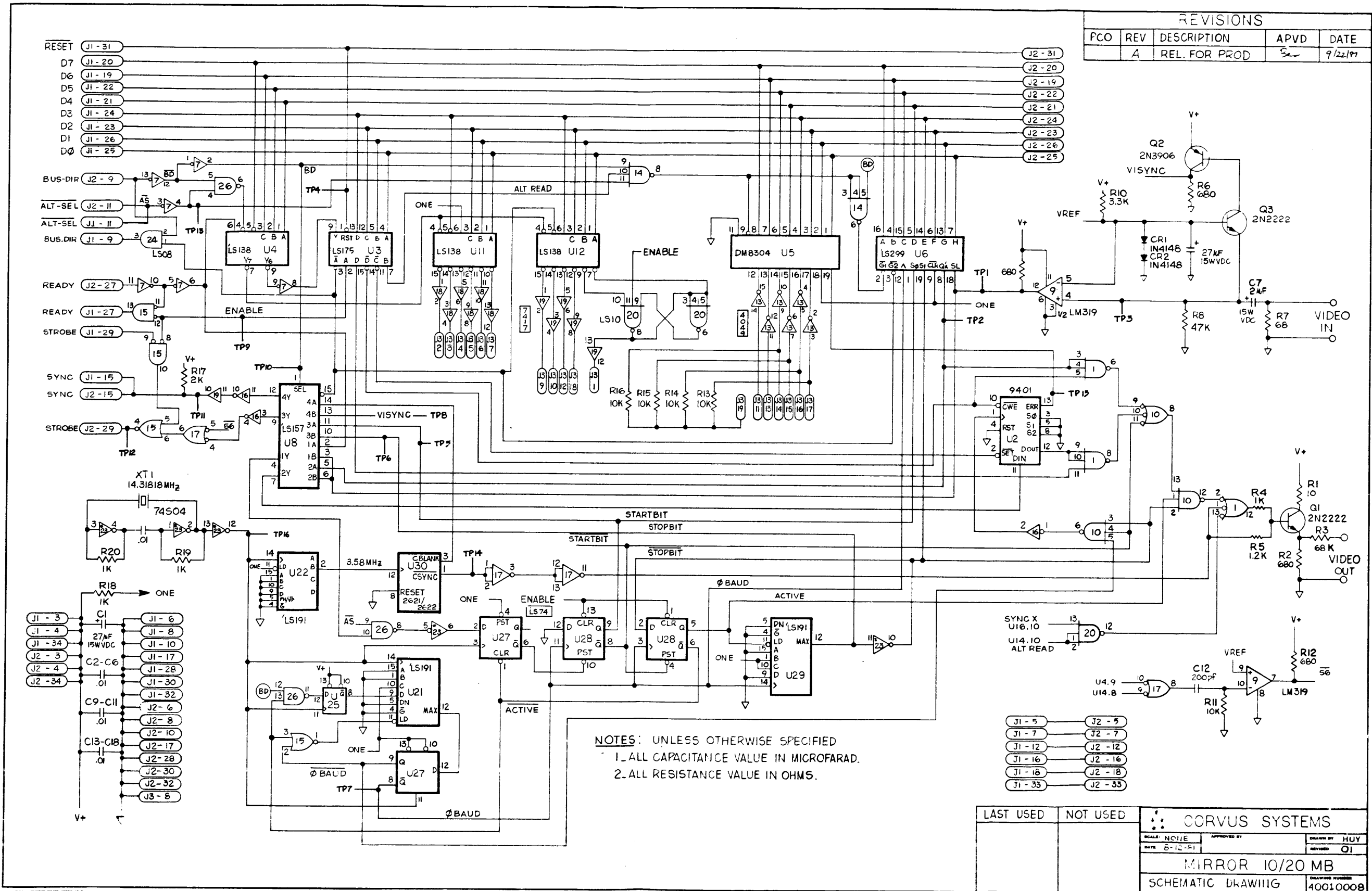

REVISIONS				
PCO	REV	DESCRIPTION	APVD	DATE
	A	REL. FOR PROD	Sc	9/22/91

NOTES: UNLESS OTHERWISE SPECIFIED
 1. ALL CAPACITANCE VALUE IN MICROFARAD.
 2. ALL RESISTANCE VALUE IN OHMS.

- J1 - 5 J2 - 5
- J1 - 7 J2 - 7
- J1 - 12 J2 - 12
- J1 - 16 J2 - 16
- J1 - 18 J2 - 18
- J1 - 33 J2 - 33

LAST USED	NOT USED	CORVUS SYSTEMS	
		SCALE: NONE	APPROVED BY: HUY
		DATE: 8-12-91	REVISED: 01
		MIRROR 10/20 MB	
		SCHMATIC DRAWING	DRAWING NUMBER: 40010008

REVISIONS				
PCO	REV	DESCRIPTION	DATE	APVD
	A	REL FOR PROD		

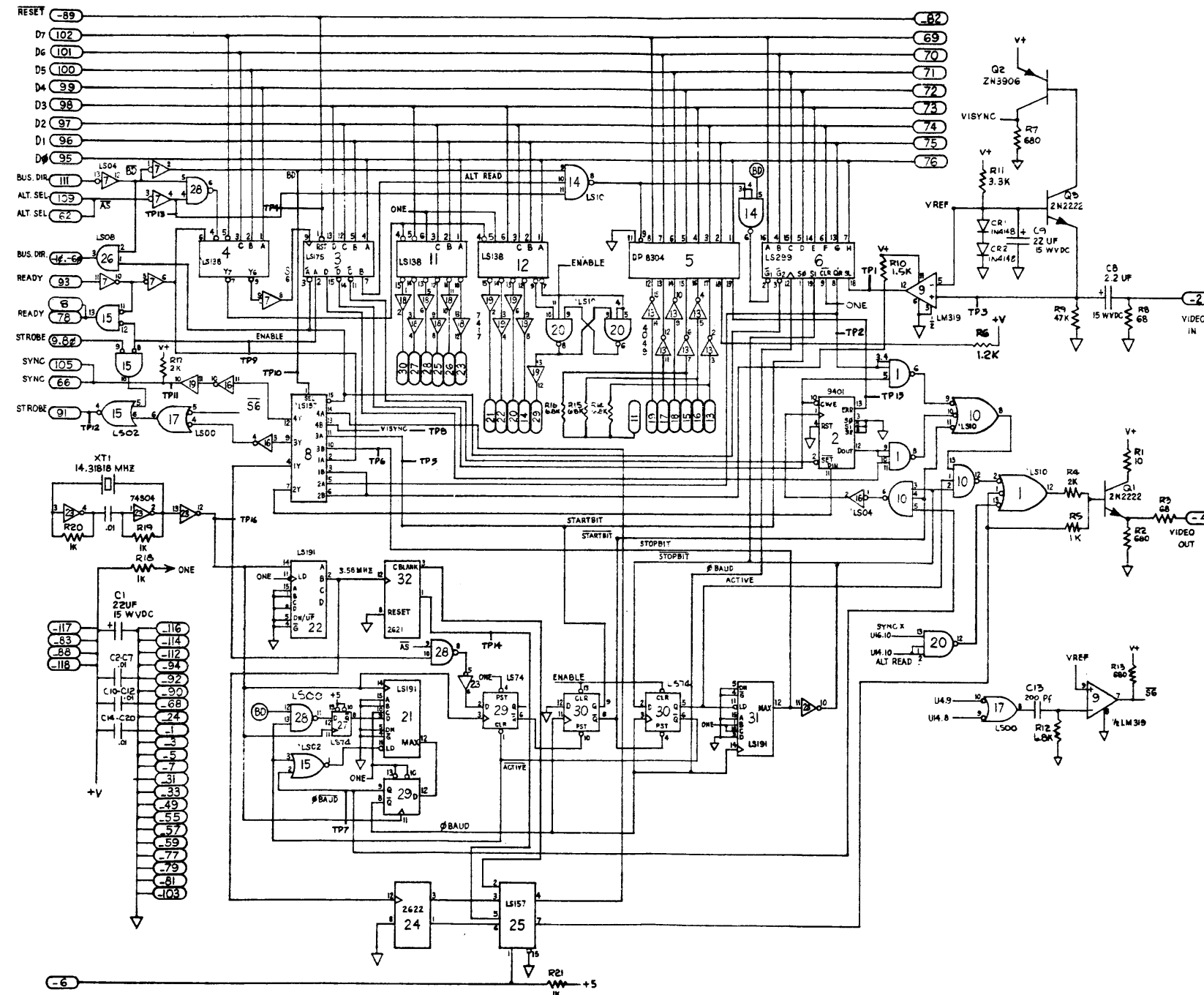

1. ALL RESISTANCE VALUES ARE IN OHMS, μ W, 5 Ω .
 NOTES: UNLESS OTHERWISE SPECIFIED

LAST USED	NOT USED
220	
CR2	
Q2	
R21	
U32	
XT1	

CORVUS SYSTEMS, INC.

SCALE:	APPROVED BY:	DRAWN BY: JRO
DATE: 3.1.81	REVISION: A	
SCHEMATIC, SMB MIRROR		
ENGR./APPROVED BY:	DRAWING NUMBER: 40010007	